

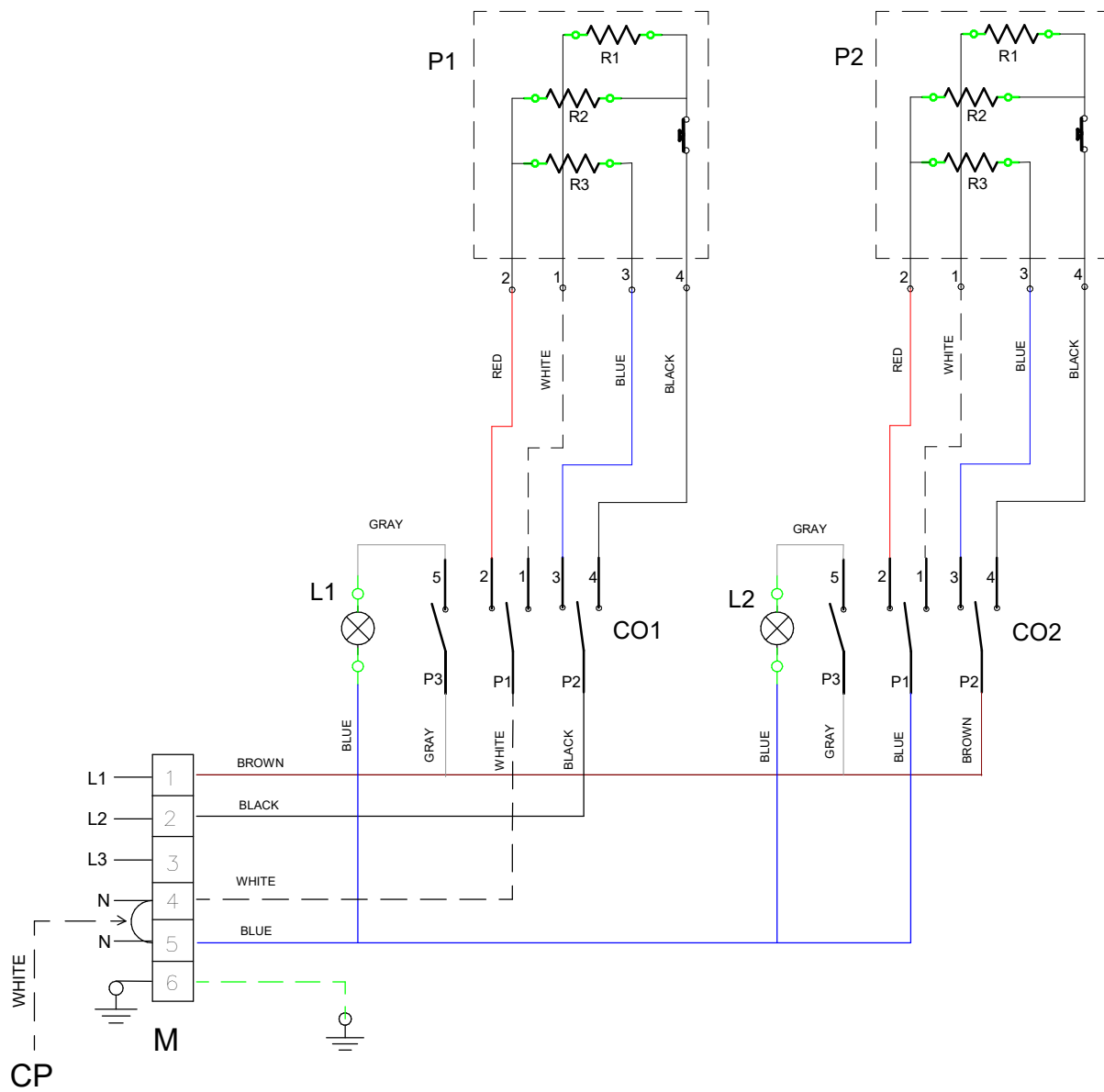

**MOD : E7/2PQ4T-N**

**Production code : DIPQ74T**

**11/2023**



CO1-CO2

|         | ITALIANO          | FRANCAIS            | ENGLISH        | DEUTSCH       |
|---------|-------------------|---------------------|----------------|---------------|
| M       | MORSETTIERA       | PENNEAU DE CONTROLE | TERMINAL BLOCK | KLEMMENLEISTE |
| CP      | CAVO PONTE        | CABLE PONT          | BRIDGE CABLE   | CABLE BRIDGE  |
| CO1-CO2 | COMMUTATORE       | COMMUTEUR           | SWITCH         | HAUPTSCHALTER |
| P1-P2   | PIASTRA ELETTRICA | PLAQUE ELECTRIQUE   | ELECTRIC HOB   | KÖCHPLATTE    |
| L1-L2   | LAMPADA VERDE     | LAMPE VERTE         | GREEN LAMP     | GRUENE LAMPE  |

|                | POSIZIONE 0 | POSIZIONE 6 | POSIZIONE 5 | POSIZIONE 4 | POSIZIONE 3 | POSIZIONE 2 | POSIZIONE 1 |
|----------------|-------------|-------------|-------------|-------------|-------------|-------------|-------------|
| PIASTRA 2600 W | 0           | 2600 W      | 1750 W      | 1300 W      | 450 W       | 340 W       | 240 W       |
| PIASTRA 2500 W | 0           | 2500 W      | 1875 W      | 1250 W      | 625 W       | 420 W       | 250 W       |
| PIASTRA 1500 W | 0           | 1500 W      | 750 W       | 500 W       | 250 W       | 165 W       | 135 W       |