

04/2013

Mod: **GS6/2FT-N**

Production code: **SP-30 GL**



Diamond
catering equipment

MODEL	NOZZLE	BURNER	12,8 kWh/kg G 30/G31 PROPAN/B UTAN 28-30 mbar	12,8 kWh/kg G 31 PROPAN 37 mbar	12,8 kWh/kg G 30/G31 PROPAN/B UTAN 50 mbar	9,45 kWh/m3 G 20 NATURAL GAS 20 mbar	8,13 kWh/m3 G 25 NAURAL GAS 20 mbar	FEEDING TUBE GAS
SP - 30 GL 6,6 kW	Nozzle of burner 1/1000 mm	Burner 3 kW	85	85	75	130	140	G 1/2"
	Nozzle of burner 1/1000 mm	Burner 3,6 kW	96	96	80	145	155	G 1/2"
	Consumption	Burner 3 kW Burner 3,6 kW	0,218Kg/h 0,262Kg/h	0,218Kg/h 0,262Kg/h	0,218Kg/h 0,262Kg/h	0,286 m3/h 0,343 m3/h	0,286 m3/h 0,343 m3/h	
SP - 60 GL 13,2 kW	Nozzle of burner 1/1000 mm	Burner 2 x 3 kW	85	85	75	130	140	G 1/2"
	Nozzle of burner 1/1000 mm	Burner 2 x 3,6 kW	96	96	80	145	155	G 1/2"
	Consumption	Burner 2 x 3 Burner 2 x 3,6	0,436Kg/h 0,524Kg/h	0,436Kg/h 0,524Kg/h	0,436Kg/h 0,524Kg/h	0,572 m3/h 0,686 m3/h	0,572 m3/h 0,686 m3/h	
SP - 90 GL 19,8 kW	Nozzle of burner 1/1000 mm	Burner 3 x 3kW	85	85	75	130	140	G 1/2"
	Nozzle of burner 1/1000 mm	Burner 3 x 3,6 kW	96	96	80	145	155	G 1/2"
	Consumption	Burner 3 x 3 Burner 3 x 3,6	0,654Kg/h 0,786Kg/h	0,654Kg/h 0,786Kg/h	0,654Kg/h 0,786Kg/h	0,858 m3/h 1,029 m3/h	0,858 m3/h 1,029 m3/h	
SP - 90 GL/5 16,8 kW	Nozzle of burner 1/1000 mm	Burner 2 x 3kW	85	85	75	130	140	G 1/2"
	Nozzle of burner 1/1000 mm	Burner 3 x 3,6 kW	96	96	80	145	155	G 1/2"
	Consumption	Burner 2 x 3 Burner 3 x 3,6	0,436Kg/h 0,786Kg/h	0,436Kg/h 0,786Kg/h	0,436Kg/h 0,786Kg/h	0,572 m3/h 1,029 m3/h	0,572 m3/h 1,029 m3/h	

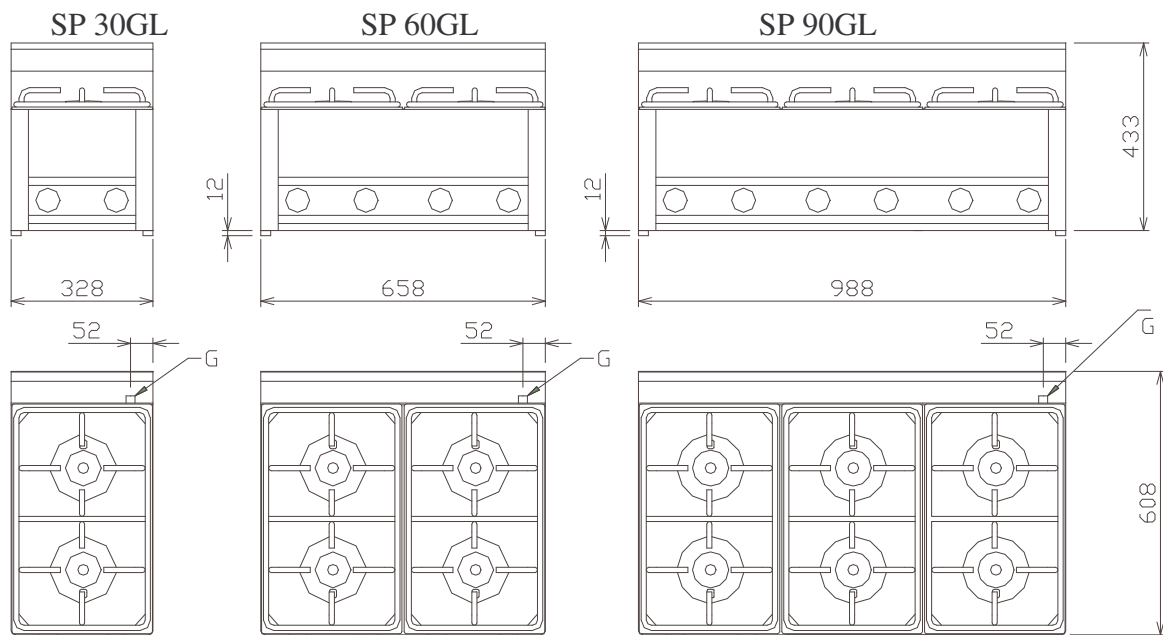

G- SUPPLY OF GAS G 1/2"