

09/2021

Mod: PFG-102/S

Production code: EQ-SMG910-HS/DI

**CONVECTION OVENS
INSTRUCTIONS FOR THE INSTALLATION, USE
AND MAINTENANCE**



FOREWORD

The contents of this manual are generic and not all the functions described may be available on your product.

The manufacturer declines all responsibility for possible inaccuracies contained in this pamphlet, due to printing or copy errors. We reserve the right to make on our own products those changes to be considered necessary or useful, without jeopardizing the essential characteristics. Read the instructions for use very carefully paying particular attention to the rules concerning safety devices. This appliance must only be used for what it has been designed for and built for and that is: all baking of dishes and regenerating pre-cooked and/or frozen food.

INSTRUCTIONS FOR USE AND MAINTENANCE

- indicate that this appliance is only for professional use and that it shall be used by qualified people;
- note that those parts which have been protected by the manufacturer or his agent shall not be adjusted by the user.

WARNING!

Before making any type of connection of this equipment (electrical or hydraulic), carefully read the instructions in this manual. This manual must be carefully kept to be available for future reference by users or service technicians. Installation must be carried out by a qualified personnel only.

1.0 DECLARATION OF CONFORMITY

The Manufacturer declares that the appliances conform to the EEC norms.

They must be installed in accordance with current standards, especially regarding aeration of the premises and the exhaust gas evacuation system.

Note: The Manufacturer declines all and every responsibility for any direct damages caused by: an incorrect use, wrong installation or bad maintenance.

1.1 EUROPEAN DIRECTIVE ROHS 2012/19/UE

This appliance is marked according to the European directive 2012/19/UE on Waste Electrical and Electronic Equipment (WEEE). By ensuring this product is disposed correctly, you will help prevent potential negative consequences for the environment and human health, which could otherwise be caused by inappropriate waste handling of this product.

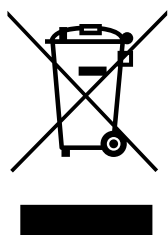

The symbol on the product, or on the documents accompanying the product, indicates that this appliance may not be treated as household waste.

Instead it shall be handed over to the applicable collection point for the recycling of electrical and electronic equipment.

Disposal must be carried out in accordance with local environmental regulations for waste disposal.

1.3 TRANSPORT OF THE OVEN AND PACKAGING REMOVAL

Upon receipt of the oven and before installing it, check the packaging is intact and there are not visible damages. Also check that along with the oven you receive also the documentation, consisting of:

- Instructions for installation, use and maintenance
- Wiring diagram
- Label ISO 3864-1

Before bringing the oven to the point, where it must be installed, check the following:

The doors are large enough to allow passage of the oven

The floor supports the weight.

According to the model of oven, its dimensions and its weight, use suitable facilities to handle goods during transport and installation, able to guarantee stability in order to avoid overturning, falls or uncontrolled movements of the appliance or its components.

Keep the oven packed until you reach the site where the oven is going to be installed.

The packaging makes the handling of goods easier and protects the oven from accidental push.

During moving and installation of the oven, the installer must comply with accident-prevention regulations in force at the place of installation (use of safety shoes, gloves, etc.) Remove the packaging taking care not to damage the oven. The adhesive film, that protects the surfaces made of stainless steel can be removed also after you have positioned the oven on the corresponding stand or the support surface.



ATTENTION: Packaging materials and adhesive film are potentially dangerous.

For this reason, they must be kept out of the reach of children and properly disposed of in compliance with local directives.

You should separate packaging materials (wood, cardboard, plastic...) and dispose of them separately, in compliance with directives in force at installation site.

Note: Take the protective film off the stainless steel parts by hand before starting the appliance.

Do not use abrasive substances and/or metal objects. Clear any adhesive residues using a sponge soaked in solvent. If the oven is heated up before removing the adhesive film, the removal of the film and cleaning of residues of glue will be much more difficult.

1.4 WARNINGS FOR THE INSTALLER

Read carefully all the instructions in this manual, because they give important suggestions about the right installation, use and maintenance of the appliance.

1.4B CONTROLS AT RECEPTION

The appliance are shipped in appropriate protective packing. On arrival, check that the appliance has not incurred in transport damage and that it is complete according to the order.

In the event of visible damage immediately note the damage on the transport documents with the following wording:

RECEIVED WITH RESERVE FOR EVIDENT DAMAGE OF PACKING.

IMPORTANT:All the operations indicated below must be performed in respect of the existing safety regulations, both for the equipment in use and for the operating procedures.

1.4C HANDLING

BEFORE BEGINNING HANDLING OPERATIONS ENSURE THAT THE LIFTING CAPACITY IS ENOUGH FOR THE APPLIANCE IN QUESTION.

HANDLING with FORK LIFT or SIMILAR (A); Insert the forks into the side or back of the wooden pallet supplied with the appliance, begin lifting checking that the appliance is in stable equilibrium. Attention: when insert the lifting device, pay attention to the power supply cable and the position of the feet.

DURING HANDLING DO NOT TIP OR TURN OVER.

THE RESPECT OF THE RECOMMENDATIONS PRINTED ON THE OUTSIDE OF THE PACKING (D) IS A GUARANTEE OF A SOUND PHYSICAL AND OPERATING CONDITION OF THE APPLIANCE, ALL TO THE ADVANTAGE OF THE END-USER. THEREFORE THE FOLLOWING IS RECOMMENDED: HANDLE WITH CARE, KEEP DRY, STACKING OF OTHER OBJECTS ON THE APPLIANCE MUST BE ABSOLUTELY AVOIDED, STACKING OF OVEN IS PERMITTED, TAKING CARE OF THE MAXIMAL QUANTITY REPORTED ON THE PACKAGING (D).

1.4D PLACING

Lift the appliance to separate it from the pallet (A). Remove the packing (B) and the protective film avoid using abrasive brushes or other damaging materials for the appliance's surfaces (C). Check that the appliance is perfectly levelled (C). Regulate the adjustable feet if it is necessary.

If you have a composition oven + neutral element, place the oven's legs in the proper place created in the top of the neutral element. Place the appliance away from heat sources and in a ventilated room. Never obstruct any air inlet on the oven in order to not compromise its performance and safety when the equipment is operating. Place the appliance in a site easy to join, so every type of maintenance, control and repair may be done easily.

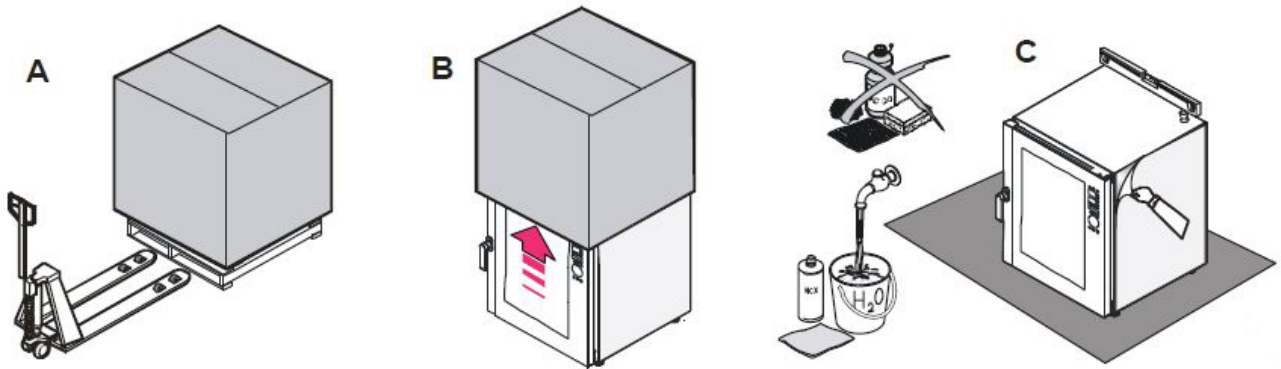

1.5 GENERAL INDICATIONS ON THE PROTECTIVE PACKING

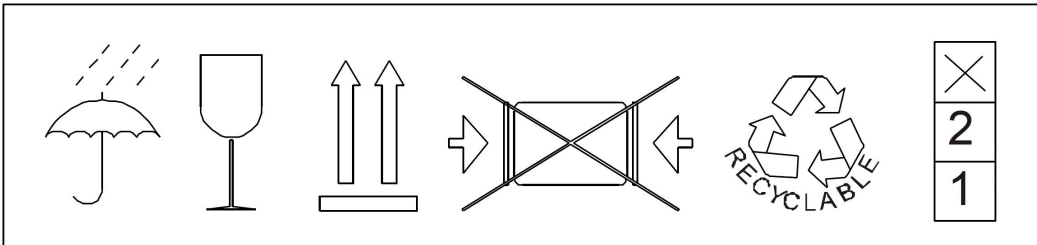







1.5B INDICATIONS ON THE PROTECTIVE PACKING OF THE GAS OVEN

GB	THIS APPLIANCE MUST BE CONNECTED FOLLOWING THE NORMATIVE LAWS IN FORCE. THIS ITEM MUST BE USED IN A VENTILATED PLACE ONLY. BEFORE THE INSTALLATION AND THE USE OF THE APPLIANCE, INSTRUCTIONS MUST BE READ DOWN CAREFULLY. THIS PACKAGING HAS TO BE PROPERLY RECYCLED ACCORDING TO THE EXISTING LOCAL REGULATIONS.	CAT II2H3+	GAS PREDISPOSED
			G20 20 mbar □ G30 28-30 mbar □ G31 37 mbar □

1.5C GAS TECHNICAL DATA PLATE

Cal	Gas	G20	G25	G30	G31				
I2E	p (mbar)	20	--	--	--	LU	<input type="checkbox"/>	PL	<input type="checkbox"/>
I3B/P	p (mbar)	--	--	30	30	IS	<input type="checkbox"/>	MT	<input type="checkbox"/>
II2H3+	p (mbar)	20	--	28-30	37	AL	<input type="checkbox"/>	CY	<input type="checkbox"/>
II2H3+	p (mbar)	20	--	28-30	37	IT	<input type="checkbox"/>	LT	<input type="checkbox"/>
II2H3+	p (mbar)	20	--	28-30	37	CZ	<input type="checkbox"/>	MK	<input type="checkbox"/>
II2H3+	p (mbar)	20	--	28-30	37	ES	<input type="checkbox"/>	CH	<input type="checkbox"/>
II2H3B/P	p (mbar)	20	--	30	30	AL	<input type="checkbox"/>	BG	<input type="checkbox"/>
II2H3B/P	p (mbar)	20	--	30	30	DK	<input type="checkbox"/>	EE	<input type="checkbox"/>
II2H3B/P	p (mbar)	20	--	30	30	LV	<input type="checkbox"/>	LT	<input type="checkbox"/>
II2H3B/P	p (mbar)	20	--	30	30	RO	<input type="checkbox"/>	SK	<input type="checkbox"/>
II2H3B/P	p (mbar)	20	--	30	30	TR	<input type="checkbox"/>		
II2H3B/P	p (mbar)	20	--	50	50	AT	<input type="checkbox"/>	SK	<input type="checkbox"/>
II2E+3+	p (mbar)	20	25	28-30	37	BE	<input type="checkbox"/>	FR	<input type="checkbox"/>
II2E3B/P	p (mbar)	20	--	30	30	RO	<input type="checkbox"/>		
II2ELL3B/P	p (mbar)	20	20	50	50	DE	<input type="checkbox"/>		
II2L3B/P	p (mbar)	--	20	30	30	RO	<input type="checkbox"/>		
II2EK3B/P	p (mbar)	20	25	30	30	NL	<input type="checkbox"/>		

1.6 TECHNICAL FEATURES

Trays	External dimensions W x D x H (mm)	Internal dimensions W x D x H (mm)	 kW	 kcal	Total Power (kW)	Absorbed Current (A)	Packed Volume (m ³)	Gross Weight (kg)
5 GN 1/1 60x40	920 x 802 x 700	660 x 420 x 450	 6,8		7,0 380 - 415 V 3N~ 50 Hz	13,7	0.65	90
10 GN 1/1 60x40	920 x 802 x 1075	660 x 420 x 825	 13,5		13,95 380 - 415 V 3N~ 50 Hz	21,4	0.95	122
5 GN 1/1 60x40	920 x 862 x 758	660 x 420 x 450		 10,0	0,22 220 - 240 V 1N~ 50 Hz	0,90	0.75	98
10 GN 1/1 60x40	920 x 862 x 1133	660 x 420 x 825		 20,0	0,45 220 - 240 V 1N~ 50 Hz	2,00	1.07	133

- It is strictly recommended to have a free space of 5 cm from the back side of the oven to the wall and from one of the two sides to the wall in order to ensure a correct and easy connection to the equipotential system and to the electrical and water system.
- It is recommended to have 4-6 cm of distance from the other appliances to guarantee a proper air circulation and avoid the near surfaces to become overheated.

1.7 ELECTRICAL CONNECTION

For the direct connection to the electric system it's necessary a device to ensure the disconnection from the electric system, with a contacts opening able to disconnect completely the electric system in the conditions of category of over voltage III, in accordance with installation regulations.

The connection must be done according to the current local regulations.

Verify that:

- Voltage and frequency correspond to those stated on the data plate of the appliance.
- The electrical plant supports the consumption of electricity of the appliance.
- The electrical plant has a grounding to the current local regulations.
- The appliance must be placed in such a way that the interlocked switched socket-outlets to the network can be easily reached.
- Type of electric cable:

Cable type	Section	Electric kW
FG7R/FG70R	5 x 4.0 mm ²	13,5
FG7R/FG70R	5 x 2.5 mm ²	9,0
FG7R/FG70R	5 x 2.5 mm ²	6,0
FG7R/FG70R	5 x 2.5 mm ²	3,35

When the appliance is operating, the power supply voltage must not diverge from the value of the nominal voltage, indicated on the data plate, by more than $\pm 10\%$.

Insert the plug in the socket only if you are sure that the socket is right for the plug. Three phases ovens are not supplied with electrical cable, therefore it is necessary to connect to the oven internal terminal board a cable of proportionate section.

Cable replacement: after opening the lower cover, placed in back side of the oven (unscrew the fixing screw), connect the conductives in accordance with the selected wiring diagram.

Fix the cable to the suitable cable gland and close the back cover.

The connection and the creation of the cable has to be done by authorized personnel.

If the cable is damaged it has to be substituted by authorized personnel.

1.7A EQUIPOTENTIAL SYMBOL



Equipotential connection is necessary when different appliances have to be connected (electrical or neutral) in an equipotential system.

1.8 WATER FEATURES

The water must be suitable to human use with the following characteristics:

Temperature: included between 15 – 20°C

Total hardness: included between 4 and 12 °f (French degrees), it is advisable to install a softener upstream from the appliance that will maintain the hardness level at the mentioned values.

Pressure: included between 150 and 250 KPa (1,5 – 2,5 bar).

Attention: higher water pressure values result in increased water consumption and can compromise the correct functioning of some components.

Maximum chloride concentration (Cl⁻): less than 150 mg/litre.

Chlorine concentration (Cl₂): less than 0.2 mg/litre.

pH: more than 7.

Water conductivity: included between 50 and 2000 µS/cm.

Attention: Water treatment systems that bring to different values to the ones above mentioned automatically invalidate the guarantee. The use of dosing systems designed to prevent the build-up of lime-scale in pipes (i.e. polyphosphate dosing systems) is also prohibited since it may impair the performance of the appliance.

1.9 GAS CONNECTION

The section of the enter gas tube depends on the gas type and on the consumption of the installed oven.

The connection must be done according to the current local regulations.

The gas oven is equipped with a 1/2" male thread positioned in the back side of the oven (see the drawing below).

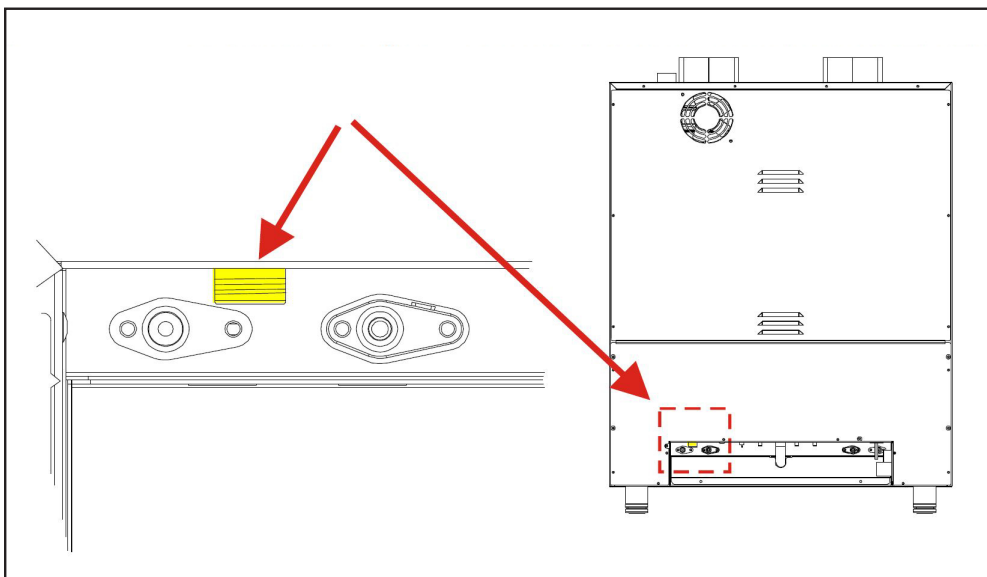

The connection has to be done with fitting adapters and gaskets appropriate for the used gas type (see technical data). A fast acting shutoff valve must be installed on the gas inlet line to the oven.

The valve must be type test approved according to the current regulations. The connections of the gas main can be permanent or detachable; if flexible metal tube is used, this should be made of stainless and corrosion resistant material (do not use rubber hose!). Every type of chosen sealing material used for connections have to be tested and approved for this purpose. All connections between the mains and the appliance must be tested for leakage.

The recommended method is to use a proprietary leak detection spray or a non-corrosive foamy liquid of any general description can simply be brushed onto the fittings: the important thing is that NO BUBBLES SHOULD APPEAR.

WARNING: NEVER ANY CIRCUMSTANCES TEST FOR GAS LEAKS WITH A NAKED FLAME.

2.0 CONNECTING TO THE FLUE

The gas appliances are provided with a flue for eliminating the residuals of combustion.

This flue must be connected as illustrated in figure as established by the installation rules.

Forced fumes evacuation type A1

The appliance is of the A1 type. It must to be installed in sufficiently ventilated rooms to prevent the possibility of unacceptable concentrations of substances harmful to health in the room in which the appliance is installed, made in accordance with national and local laws and regulations in force.

Indicatively the flow rate of an air aspirator connected directly to the external environment is 35 m³/h for each kW of gas power installed.

The appliance must be installed in sufficiently ventilated rooms to ensure the air flow necessary for combustion, in accordance with the national and local laws and regulations in force.

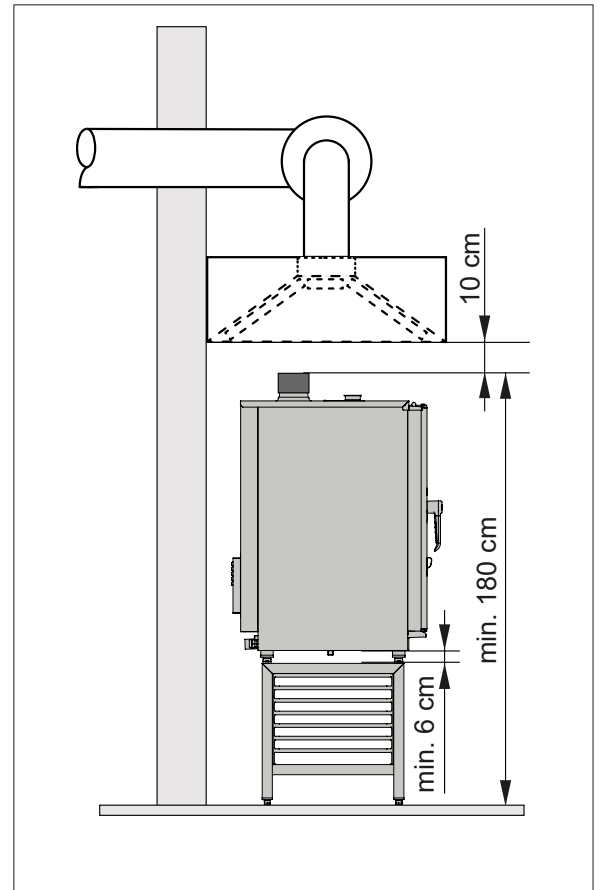

2.1 PLUMBING – WATER DRAINAGE

Drainage for the water is at the back of the oven and must be connected directly to the end of the stainless steel drainpipe.

The drain must have no trap and be made in rigid pipes that can withstand a temperature of 110°C.

Under no circumstances must pipe diameter be reduced. The actual pipe should be at atmospheric pressure with the appropriate funnel type air intake.

If the drainpipe is clogged for any reason steam can escape from the door and bad smells can be created inside in the oven.

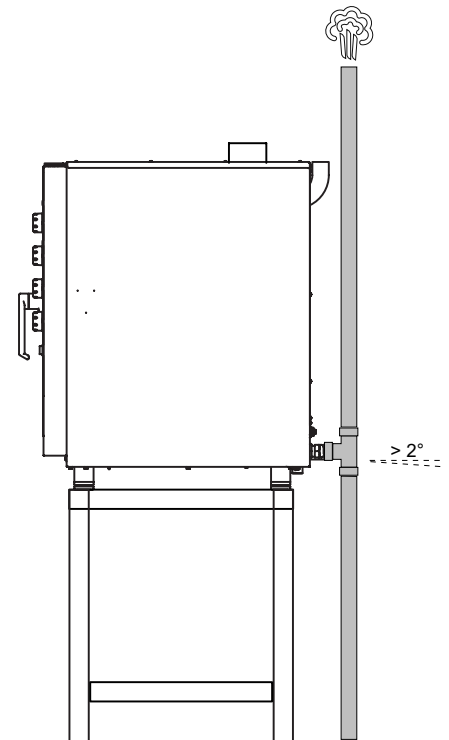

3.1 REPLACING SPARE PARTS

The replacement of damaged parts must be done only by qualified personnel. To request the manufacturer parts to be replaced must be provided the oven model and serial number.

These data can be found on the rating plate attached to the oven.

Before starting to replace spare parts make sure, for safety reasons, that the electricity main switch is off and that the water on-off valve are closed.

3.2 CHECKING THE FUNCTIONS

After completing the installation of the oven is necessary to perform a leak test to the water network.

The installer must check with suitable measurement instruments that the air noise emissions have a level of sound pressure type weighed A, less than 70 dB (A).



The label ISO 3864-1 here on the side must be stuck on a visible surface, 1,6 mt height from the ground.

On floor models, the label is already stuck in the suitable position.

On table models, the label is supplied along with the documentation and must be stuck after installation on a visible part of the appliance at 1.60 mt from the ground.

The installer must verify proper operation of the oven, providing the necessary instructions to the customer and give this instruction manual that the user must follow carefully.

IMPORTANT:

Before the operator turns the oven on and uses it for any cooking or washing cycle, it is necessary that the installer or a qualified technician checks all the connections have been done up to the instructions stated in our manual.

The technician or the installer must therefore check as follows:

- The oven must stand (horizontal position) and be fixed on a stand or a shelf, that can guarantee stability.
- Wiring connection must be effected according to the directives and the feed cable section must be no lower than the one indicated in the manual.
- Pressure and hardness of the water must comply the values indicated in this manual;
- If the oven is supplied with drain pipe, this must be connected properly and the materials used should withstand the working temperature.

After you have checked everything, open the water on-off valve, eventually the gas on-off valve and the protection switch, all installed upstream.

The installer must check the proper functioning of the oven and give to the operator necessary instructions for a correct use of the oven, and also verify that the operator owns a copy of this manual.

3.3 GAS OVENS: SOSTITUTION OF NOZZLES

TABLE FOR NOZZLE SUBSTITUTION

THERMIC NOMINAL POWER	NOZZLES		MARKING
10.0 kW	G30 30 mbar		80
	G20 20 mbar		120
20.0 kW	G30 28..30 mbar	G31 30...37 mbar	110
	G30 50 mbar	G31 50 mbar	95
	G20 20 mbar		175
	G25 25 mbar		185
	G25 20 mbar		195

You have to close the gas tap before make any operation.

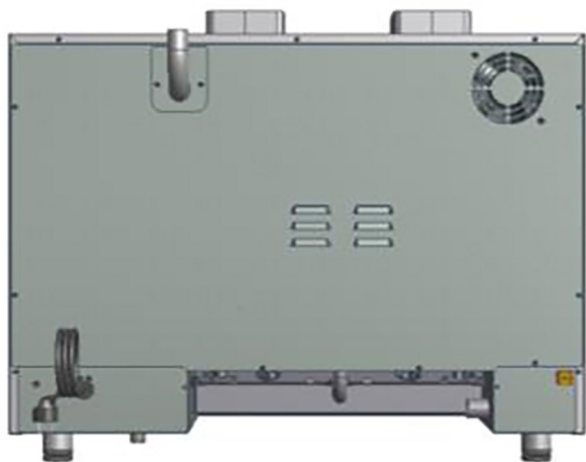

Unscrew the screws of the cover panel of the burner.

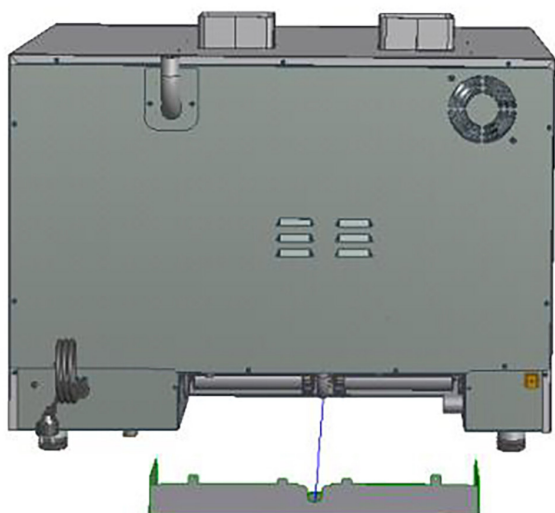

Nozzle ----->

Gasket ----->

Remove the lower panel of the burner.



Unscrew the screws of the left and right burner.



Remove the left burner and the right one.



After removing the burners, burner nozzles unscrew the two left and two right of burner nozzles.

- Throw away the old nozzles and gaskets.
- Mount the new nozzles in the place of the old ones .
- Mount again the burners and fix them with their own screws.
- Mount the burner lower panel and fix it with its own screws.
- Open the gas tap.

4.0 PROBLEMS AND SOLUTIONS

THE OVEN DOES NOT SWITCH ON

- Check that all pole disconnection switch is switched on and that there is power (green light on)
- Set the timer
- Check if the safety thermostat has to be reset
- Check that the oven's door is closed
- Check the cooking session has been correctly set.

THE FAN SWITCHED OFF WHILE THE OVEN IS ON

Every 2 minutes the fan motor automatically reverses direction of rotation followed by a 20-seconds rest. If the last cooking session ended with the fan rest period, the next time, you switch the oven on, the motor will remain briefly switched off .

- Check that the fan is not temporarily switched off (no more than 20 seconds) due to the normal functioning of the oven.
- Check that the oven's door is closed
- Check that the vent is not obstructed.

THE OVEN CHAMBER LIGHT DOES NOT WORK

- Use heat-resistant light bulbs
- Replace the light bulbs

HUMIDITY CONTROL TUBES ARE NOT DISCHARGING WATER

- Check that the water tap is open.
- Check that the filter is not obstructed
- Check that the humidity control has been switched on

WATER FILTER

If the water supply to the oven is interrupted , check the electrovalve input filter behind the oven:

- Turn off the water tap on the rising main
- Disconnect the tube connecting the oven to the mains
- Use pliers to remove the filter located behind the electrovalve
- Clean filter of any impurities and replace it behind the electrovalve
- Reconnect the tube

RED LIGHT ALARM

Means that the burner is blocked. You have to press for 3 seconds the re-start button (see installation scheme).

4.1 ORDINARY MAINTENANCE

This section is dedicated to the end user and is important for the appliance to work correctly in the long term. A few simple operations conscientiously carried out at set periods can avoid the need of servicing by specialised personnel.

The operations to be made do not require any particular technical knowledge and can be summarised in simple controls of the appliance components.

BEFORE BEGINNING ANY TYPE OF MAINTENANCE OR CLEANING WORK ON THE APPLIANCE DISCONNECT THE MAINS POWER SUPPLY (electric, water).

OVEN'S CLEANING

ATTENTION: BEFORE CLEANING THE OVEN YOU HAVE TO ENSURE THAT THE OVEN IS COLD.

At the end of the working day, clean the oven inside and out:

1. use only warm water and soap or a neutral detergent
2. rinse with plenty of water dry thoroughly
3. dry thoroughly

All food residuals and grease must be removed from the oven each time it is used for cooking; follow the 1-2-3 indications below.

Do not use abrasive materials and other products which could be damaging for the inox surfaces.

Use only alkali based products suitable for the purpose.

Do not use high pressure water jets to clean the oven.

If the oven does not work properly, switch the oven off, disconnect the electricity and water supply and notify the technical assistance service.

For an extended period of non use we recommend to:

1. switch off the appliance by long pressing the (1) ON/OFF key
2. disconnect from all powers supply electric and water
3. leave the door ajar to avoid bad odors from forming

The appliance should be checked at least once a year by qualified and authorised personnel.

USE AND MAINTENANCE

INSTRUCTIONS FOR A SAFE USE OF THE OVEN

- Ensure the oven is on a stable position and safety devices installed upstream are efficient.
- Always use adequate protection gloves to introduce or pull out the trays.
- Always pay maximum attention to the floor, that due to cooking steam could be slippery.
- In order to avoid burns, never use trays or containers with liquids or fluids over a level that can be easily controlled at sight.
- Don't put trays or other kitchen tools on the oven.
- Periodically have a check with technical service and replace eventual damaged parts, that could alter the proper functioning of the oven or be a danger.
- Often clean the oven following the instructions stated in this manual.

MAX. FOOD LOADING

Number of trays	Max. food loading
5 x 1/1 GN - 60x40	15 kg
10 x 1/1 GN - 60x40	30 kg

For a correct comprehension of the terminology used in the following paragraphs, we underline that **cooking phase is the period of time in which the oven carries out one of the following cooking modes:**

Convection

(temperature range between 50 - 270°C)

Convection with steam

(temperature range between 50 - 270°C)

5.0 CONTROL PANNEL DESCRIPTION

A	Thermostat
B	Timer
C	Humidity regulation
D	Temperature display
E	Low ventilation
F	Reset gas
G	Release valve

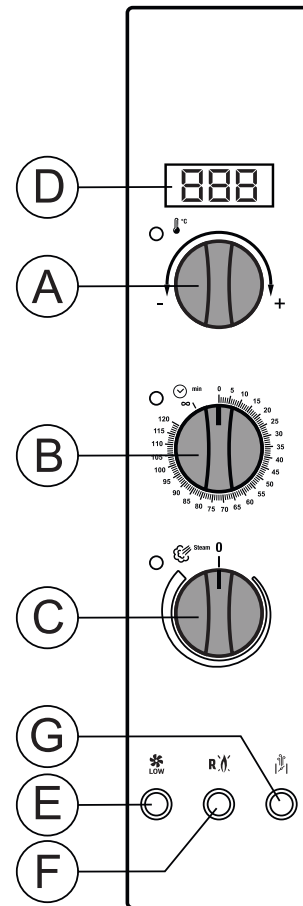

5.5 STARTING THE OVEN

Ensure that water supply are turned on, eventually gas valve is open and that the electricity supply is switched on. Turn the oven on using the power switch located below the control panel.

5.6 COOKING CHAMBER PREHEATING

It is always advisable to pre-heat the oven before cooking food.

The time needed to heat the oven should be set taking into account that in the hot air convection cycle it takes about 10 minutes to reach 220°C.

Having selected the desired time and temperature, switch the oven on without food inside.

Once the oven reach the preset temperature you can put the meals to cook into the oven. When the oven door is re-closed, the oven starts the cooking.

5.7A TEMPERATURE SETTING

Rotating the knob A is possible to set the cooking chamber temperature.

The display D will show the setted temperature

5.7B COOKING TIME SETTING

To set a cooking time till 120 minutes, rotate the knob B in clockwise direction.

It is also possible to set an infinite cooking time (continuous mode). To set the infinite cooking time rotate the knob B anticlockwise till the symbol ∞ .

5.7C HUMIDITY REGULATION

In this oven it is possible to adjust the amount of humidity by turning knob C. The moisture added to the hot air helps keep food moist, preventing it from drying out during cooking.

5.7D VENTILATION SPEED

This oven has 2 fan speeds. Reduced ventilation dries food less than normal, thus helping to keep it moist and soft. The reduced speed is activated by switch E.

5.7E RELEASE VALVE

Switch G opens and closes the vent valve. The opening of the valve favors the escape of excess steam from the cooking chamber. Opening the valve is essential for obtaining dry and crunchy food.

5.7F RESET GAS

Using button F, when it's lighting, is possible to retry to light the burner after a failed attempt. (Only gas models).

5.8 SWITCH OFF THE OVEN

The oven has an ON / OFF switch located under the oven control panel.

9.0 MAINTENANCE

It is compulsory to turn the main switch off and close the water on-off valve, both installed upstream from the oven before servicing it. The oven should be cleaned at the end of each working day, using specific products only.

9.0A CLEANING OF EXTERNAL PARTS

All external stainless steel parts should be:

- cleaned with clear, soapy water;
- rinsed with water;
- dried thoroughly.

It is absolutely forbidden to use scrapers, metal soap pads and other common steel tools as they could besides scratching the surface, deposit iron particles that, oxidizing would cause rust to form.

DO NOT WASH THE APPLIANCE WITH JETS OF WATER.

DO NOT USE PRODUCTS TO WASH THE STAINLESS STEEL PARTS, WHICH CONTAIN CHLOR (BLEACH, CHLORINE ACID) EVEN IF WATERED DOWN.

9.0B COOKING CHAMBER CLEANING

The oven cooking chamber must be cleaned from residues of food and fat at the end of each cooking process. Proceed as follows:

- Heat the oven at a temperature of 80-90°C in steam mode to soften the dirty.
- Vaporize the internal part of the cooking chamber with a specific detergent suitable for stainless steel.
- Rinse with a lot of water using a sponge or a hand shower.

ANY RESIDUES OF DETERGENT COULD DAMAGE THE PARTS IN STAINLESS STEEL WHEN THE COOKING CHAMBER WILL BE HEATED UP.

The fan must be kept clean to avoid grease and fat from depositing on the blades causing motor revolutions to decrease leading to a reduction in the flow of air and dangerous mechanical stress to the motor itself.

9.1 WHAT TO DO IN CASE OF A BREAKDOWN AND/OR EXTENDED PERIOD OF NON USE

If the oven does not work properly, breaks down or if the safety thermostat triggers, switch the oven off, disconnect the electricity and water supply and notify the technical assistance service.

All work of installation, maintenance and repairs should be carried out exclusively by qualified and authorized personnel.

10.0 COOKING TIPS

To obtain the best results, we advise to use **GAS-TRONORM** trays, available in different models and materials according to the type of cooking.

It's fundamental always to **leave an interspace of 3 cm at least** between the food to be cooked and the upper tray for a good air circulation.



The height of the food should be similar to the height of the trays. Very low layers of food in trays of 65 and 80 mm can cook in a non uniform way.

It is advisable to avoid the food to be cooked overflows from the pan , or in case this is not feasible, avoid placing the pan on the top floor to that affected by the situation described.

Cooking of different food can be performed simultaneously at the same temperature , avoiding the overlapping of flavors, placing the products with stronger flavor always on the top of the cooking chamber and the release valve must to be open.

For an optimal cooking temperature you must take into consideration the following rule: select a lower temperature of about 20 % compared to the one set in traditional static ovens without ventilation.

The forced ventilation system, of which this oven is equipped, ensures cooking in reduced time.

Convection cooking with 0% humidification: this method, commonly called "Convection", is indicated for all types of cooking where you want to get dry and crispy food. To achieve this result it is advisable to open the release valve to help the exhaust of steam from the cooking chamber.

Convection cooking with humidification: this method, commonly called "combined" is indicated for all types of cooking where you want to get soft and juicy food.

10.1 REMEDIES TO COOKING HITCHES

If cooking is uneven:

Check that there is at least 3 cm between the food cooking and the tray above it: if there is less space it will not allow correct ventilation of the food to be cooked.

- Make sure that the foods to cook are not against each other which would prevent correct ventilation between them.
- Cooking temperature might be too high, try with a lower temperature.
- The preheating has not been effected. If you introduce the products with cold cooking chamber, it will take a much longer time to reach the selected temperature than the one requested by preheating. During this phase the ventilation and the temperature inside the cooking chamber could not be uniform and produce therefore a loss of cooking uniformity.
- Frozen food has been introduced in the oven. In this case it's advisable to the food at a temperature of 40-50 °C and then proceed with cooking.
- The oven drain could be obstructed and alter the ventilation inside the cooking chamber.
- The door gasket could not be steam tight. The steam coming out from the door could alter the ventilation.

If the food is dry:

- Reduce cooking time.
- The temperature must be adequately lowered.
- Remember that the lower the temperature is the less weight will be lost.
- The combined cycle for a humidity rich cooking environment was not selected.
- The food was not greased with oil or juices before it was put in to cook.