

07/2021

# **Mod:WR-FTE-M1**

**Production code:FTH-30E\_**

# electric griddle plates

Snack units are made of AISI 430 stainless steel with AISI 304 top plate. All snack units include pressed top plate or basins with round internal angles and ergonomic front panels. All connection points are located on the device rear side. Wide selection of models and options helps in setting up a compact customized configuration.



- Selection of modules of 330, 660, 990 mm width
- The option of several surface variants and the plate materials. Smooth or ribbed surface, the option of surface combination. The plate material is steel or hard chrome steel
- Griddle plate thickness is 10 mm – it guarantees smaller temperature fluctuation
- Plate rim (space coverage) is welded on both sides
- Fat drawer with 1 litre volume
- Simple control by means of the main switch and regulation knob
- Possible variant with safety thermostat
- Delivered with stainless steel scraper for cleaning burnt items



FTH 30 E  
FTHC 30 E



FTR 30 E  
FTRC 30 E



FTH 60 E  
FTHC 60 E



FTHR 60 E  
FTHRC 60 E



FTH 90 E  
FTHC 90 E

Index	Model	mm	kg	V / Hz	kW	Plates	Plates	° C
101 000 100 101 001 800	FTH 30 E FTHC 30 E	330 x 540 x 220	23,7	230 / 50-60	3	480 X 320	Smooth Smooth chromed	50 - 300
101 000 500 101 000 502	FTR 30 E FTRC 30 E	330 x 540 x 220	23,7	230 / 50-60	3	480 X 320	Grooved Grooved chromed	50 - 300
101 001 000 101 001 005	FTH 60 E FTHC 60 E	660 x 540 x 220	40,6	400 / 50-60	6	480 x 650	Smooth Smooth chromed	50 - 300
101 001 500 101 001 502	FTHR 60 E FTHRC 60 E	660 x 540 x 220	40,6	400 / 50-60	6	480 x 650	Combined Combined chromed	50 - 300
101 000 900 101 000 910	FTH 90 E FTHC 90 E	990 x 540 x 220	69	400 / 50-60	9	480 x 970	Smooth Smooth chromed	50 - 300

# electric griddle plates

## FT 30

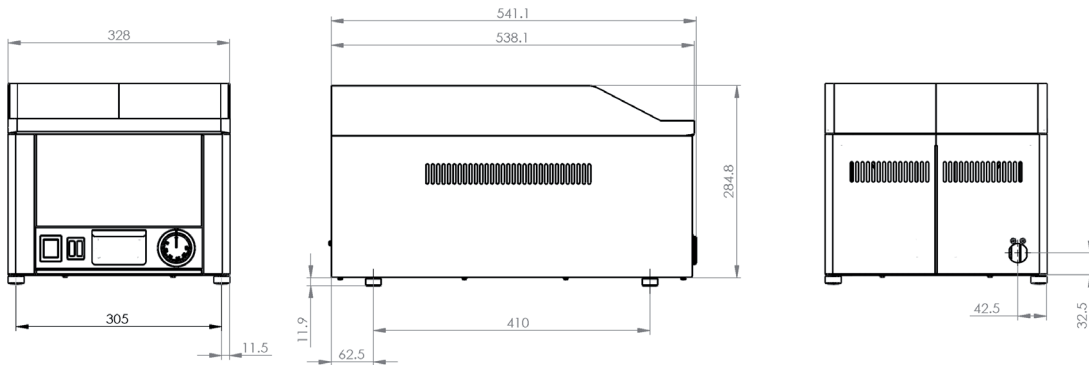

## FT 60

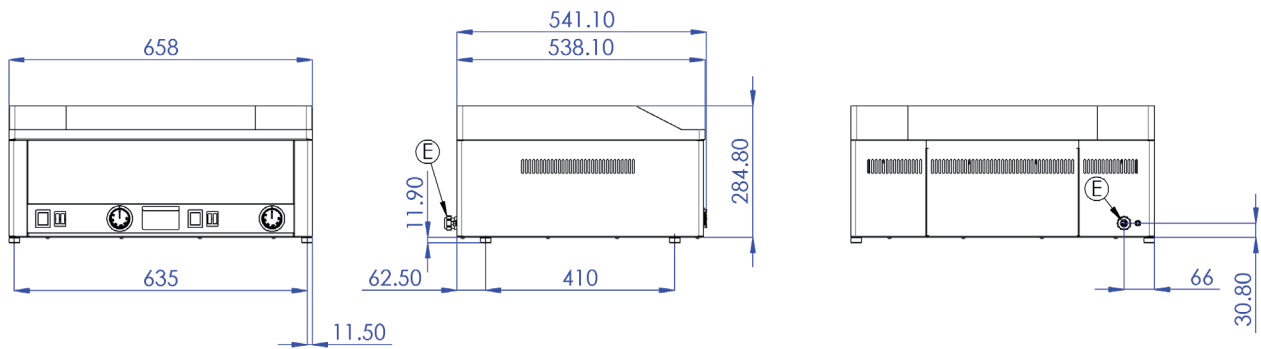

## FT 90

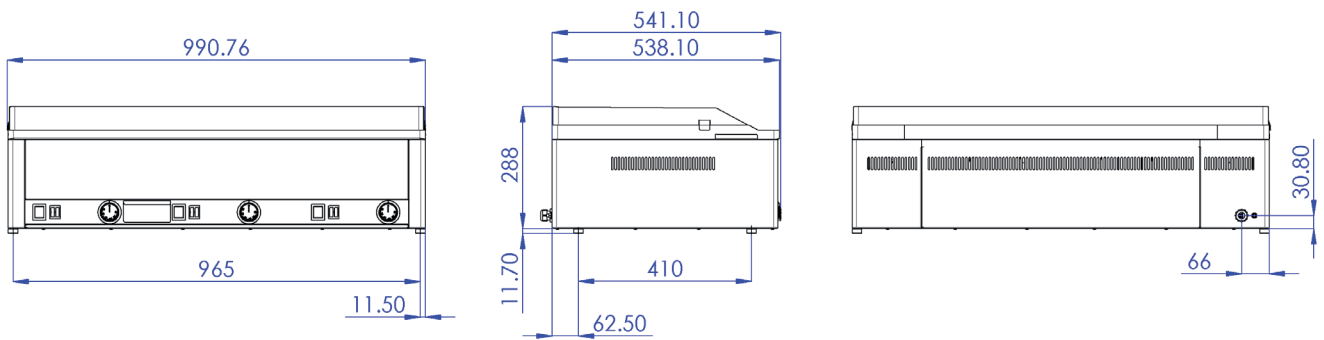

E - electric