



MOD : E65/SF4T-N

Production code : F65/40SPE/T

03/2024

1

2

3

4

5

6

A

A

65/40 SPE
70/40 SPE

B

B

C

C

D

D

E

E

F

F

G

G

H

H

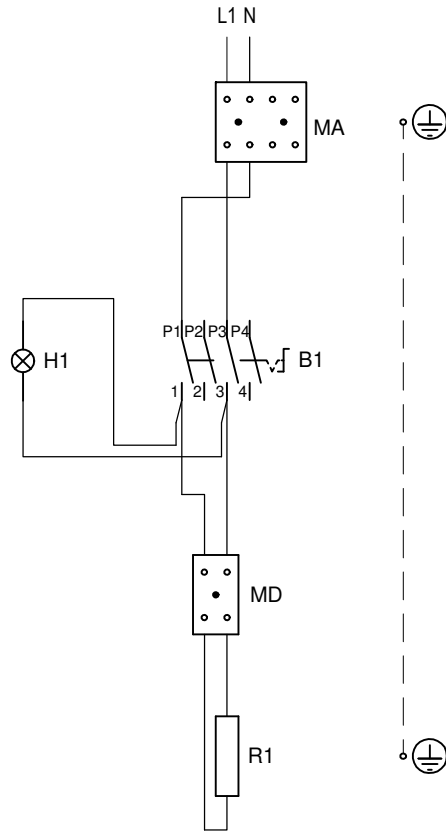

B1 INTERRUTTORE _ INTERRUPTEUR
SWITCH _ SCHALTER _ INTERRUPTOR

H1 LAMPADA SPIA VERDE _ LAMPE TEMOIN VERTE
GREEN INDICATOR LIGHT _ GRUENE KONTROLLAMPE _ INDICADOR LUMINOSO VERDE

MA MORSETTIERA ARRIVO LINEA _ BORNES ARRIVE LIGNE
POWER INLET TERMINAL BOARD _ ANSCHLUSSBRETT _ BLOQUE TERMINAL LÍNEA

MD MORSETTIERA DERIVAZIONE _ SHUNT JUNCTION-BOX _ BORNES DE DERIVATION _ ABZWEIGKLEMME _
BLOQUE TERMINAL DERIVACIÓN _ AFLEIDINGSKLEMMENBLOK

R1 RESISTENZA _ RESISTANCE
HEATING ELEMENT _ HEIZKOERPER _ RESISTENCIA



Prima di intervenire sull' apparecchiatura, scollegare l' alimentazione elettrica - Unplug the power supply before operating on the appliance
Bevor am gerät arbeiten ausschalten srè die elektrische speisung
Avant d'intervenir sur l'appareil, déconnectez l'alimentation électrique - Desconectar el alimentaciòn antes cualquier intervenciòn sobre el aparato

SCALDAPATATE
POMMES FRITES WANNE
ELEMENT CHAUFFANT-FRITES
FRENCH-FRIEDHOT CANTAINER

MOD. :

/
SPE
/

data: 23/08/2005

CODICE

nome: Pasquot

251.027.00

mod.: 23/08/2005

FOGLIO: 1/1

Pot.(kW) 1 vol(t)(VAC) 220-240 V ampere(A)

5 hertz(Hz) 50-60