



MOD : E65/BM7T-N

Production code : F65/70BME/T

03/2024

1

2

3

4

5

6

A

A

B

B

C

C

D

D

E

E

F

F

G

G

H

H

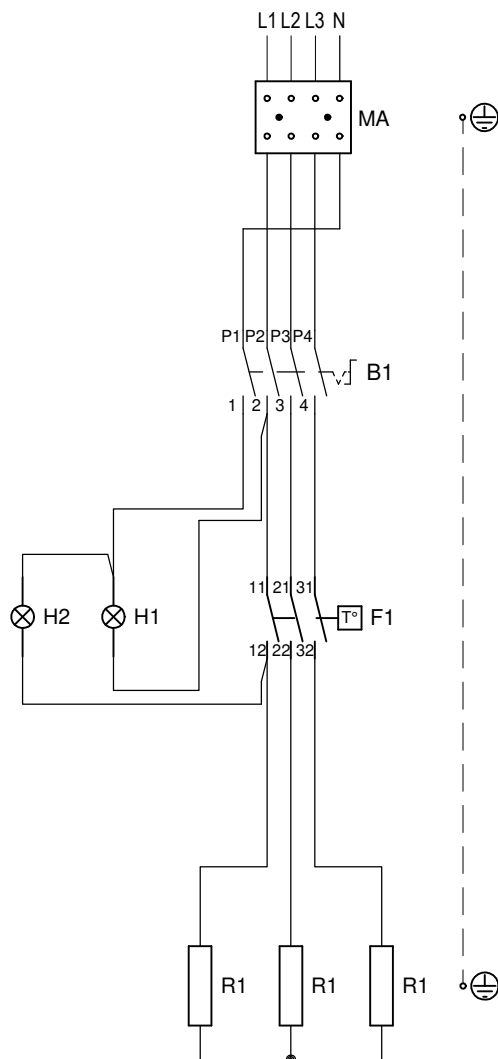

B1 INTERRUTTORE _ INTERRUPTEUR
SWITCH _ SCHALTER _ INTERRUPTOR

F1 TERMOSTATO _ THERMOSTAT
TERMÓSTATO

H1 LAMPADA SPIA VERDE _ LAMPE TEMOIN VERTE
GREEN INDICATOR LIGHT _ GRUENE KONTROLLAMPE _ INDICADOR LUMINOSO VERDE

H2 LAMPADA SPIA ARANCIO _ LAMPE TEMOIN ORANGE
ORANGE INDICATOR LIGHT _ ORANGE KONTROLLAMPE _ INDICADOR LUMINOSO NARANJA

MA MORSETTIERA ARRIVO LINEA _ BORNES ARRIVE LIGNE
POWER INLET TERMINAL BOARD _ ANSCHLUSSBRETT _ BLOQUE TERMINAL LÍNEA

R1 RESISTENZA _ RESISTANCE
HEATING ELEMENT _ HEIZKOERPER _ RESISTENCIA



Prima di intervenire sull' apparecchiatura, scollegare l' alimentazione elettrica - Unplug the power supply before operating on the appliance
Bevor am gerät arbeiten ausschalten srè die elektrische speisung
Avant d'intervenir sur l'appareil, déconnectez l'alimentation électrique - Desconectar el alimentación antes cualquier intervención sobre el aparato

BAGNOMARIA
BAINMARIE
WASSERBAD
BAÑOMARIA

MOD.

_65/70 BME
BME/70 A
_70/70 BME...

data: 24/08/2005

CODICE

nome: Pasquot

251.074.00

mod.: 24/08/2005

FOGLIO: 1/1

Pot.(kW)

3

volt(VAC)

380-415 V 3N

ampere(A)

5

hertz(Hz)

50-60