



MOD: E65/4P7T-N

Production code : F65/70PCE/T

04/2024

1

2

3

4

5

6

A

A

B

B

C

C

D

D

E

E

F

F

G

G

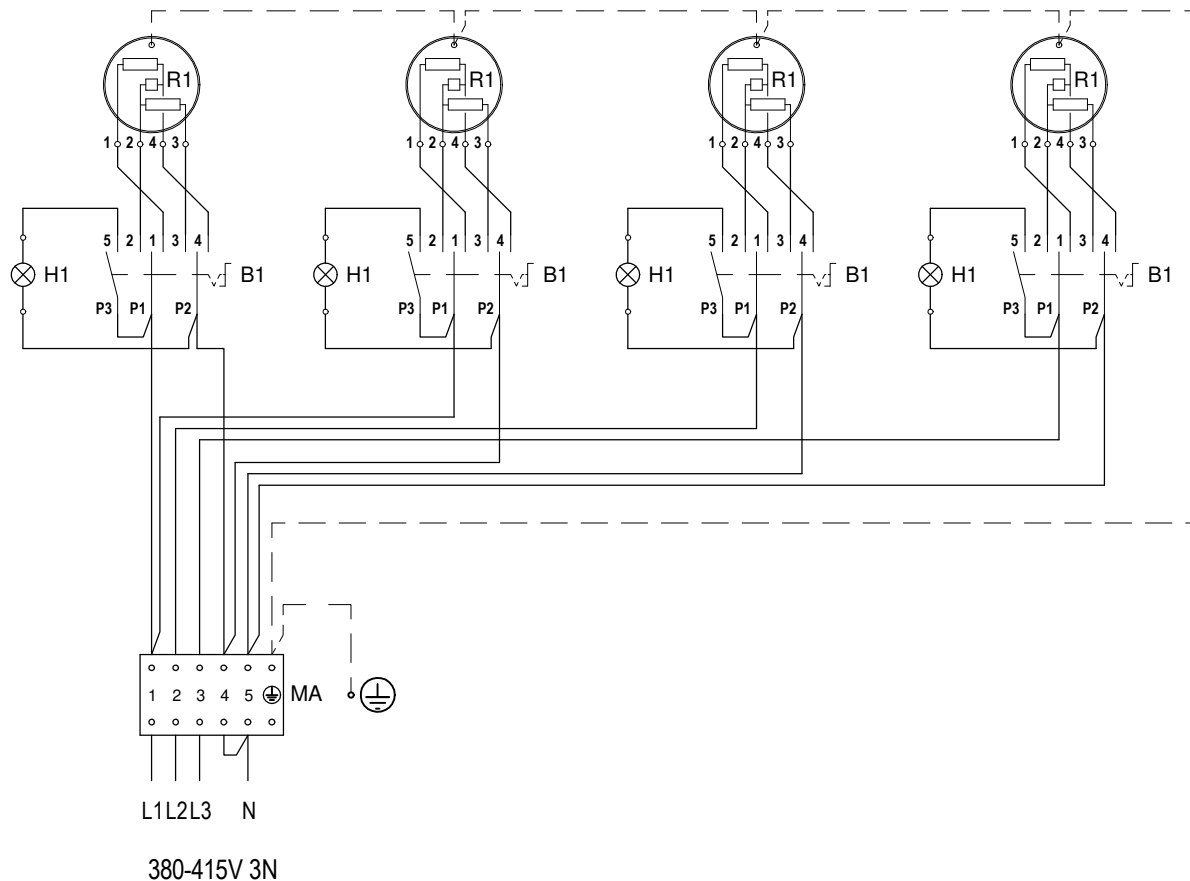

B1	COMMUTATORE	CHANGE-OVER SWITCH	UMSCHALTER	COMMUTEUR
H1	SPIA VERDE	GREEN INDICATOR LIGHT	GRUENE KONTROLLAMPE	LAMPE TEMOIN VERTE
MA	MORSETTIERA ARRIVO LINEA	POWER INLET TERMINAL BOARD	ANSCHLUSSBRETT	BORNES ARRIVE LIGNE
R1	PIASTRA ELETTRICA	ELECTRIC PLATE	ELEKTROKOCHPLATTE	PLAQUE ELECTRIQUE



Prima di intervenire sull' apparecchiatura, scollegare l' alimentazione elettrica - Unplug the power supply before operating on the appliance
 Bevor am gerät arbeiten ausschalten srè die elektrishe speisung
 Avant d'intervenir sur l'appareil, déconnectez l'alimentation électrique - Desconectar el alimentaciòn antes cualquier intervenciòn sobre el aparato

H

H

PIANO COTTURA ELETTRICO
 TABLE DE CUISSON ELECTRIQUE
 ELECTRIC COOKING TOP
 ELEKTROKOCHFELD
 PLANO DE COCCION ELÉCTRICO

MOD.

_65/70 PCE

_70/70 PCE...

/

data: 21/02/2020

nome: FRANCESCO

mod.: 22/08/2005

CODICE

251.072.00

FOGLIO: 1/1

Pot.(kW)

10,4

volt(VAC)

380-415 V 3N

ampere(A)

24

hertz(Hz)

50-60