

**Mod: EERV**

**Production code: EFP01**

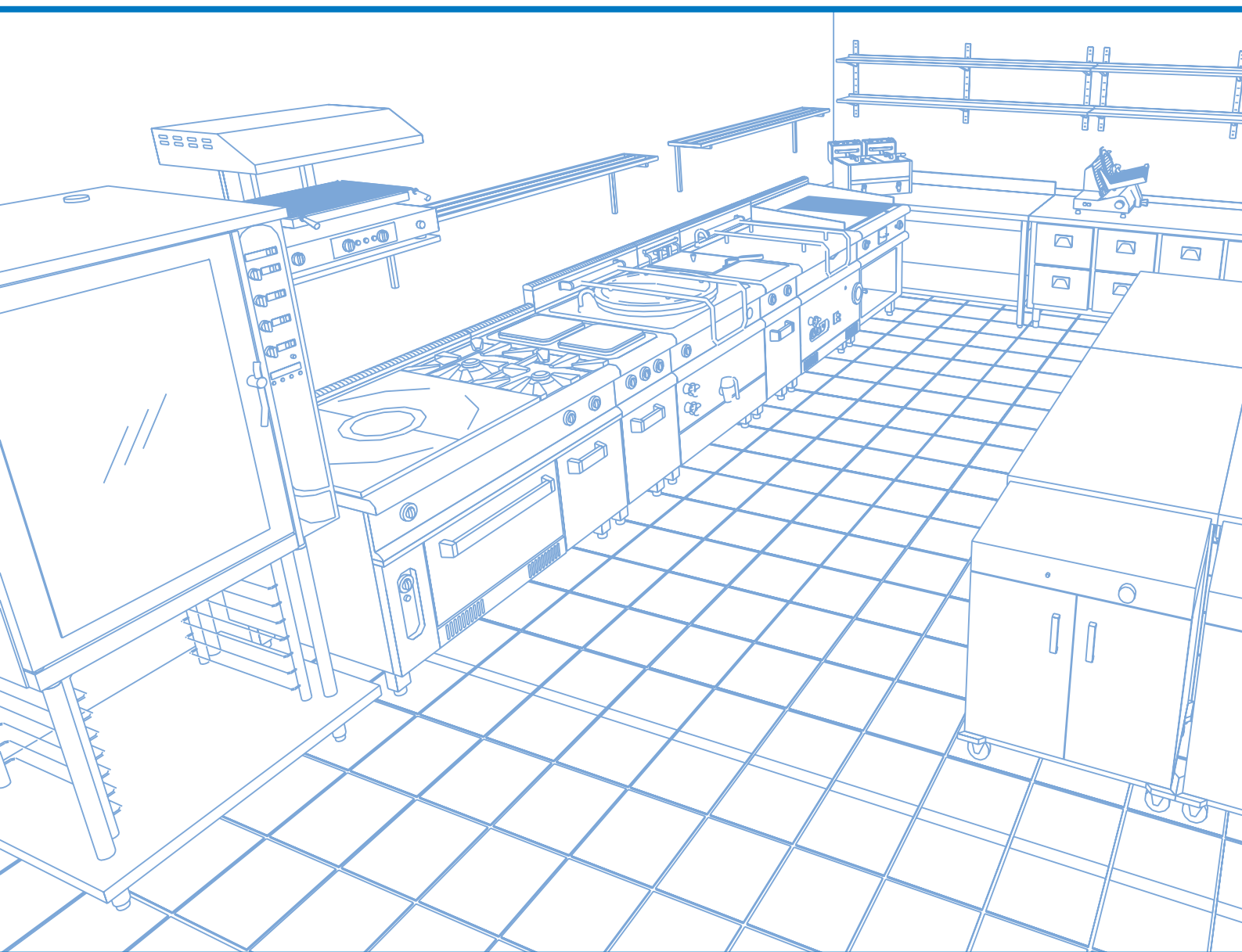

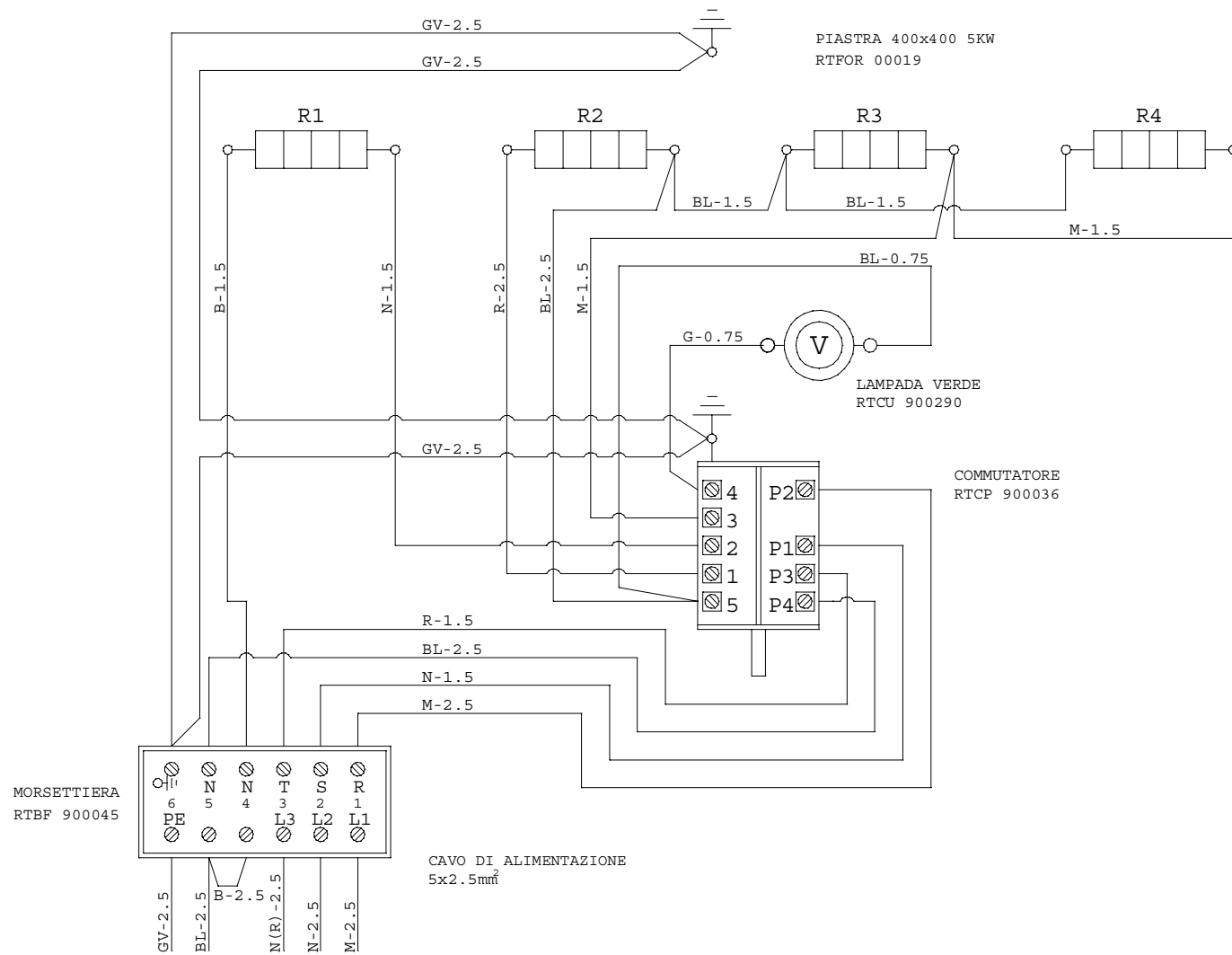

COLORE COLLEGAMENTI EL.:

- G-V = GIALLO-VERDE
- M = MARRONE
- N = NERO
- BL = BLU
- G = GRIGIO
- V = VERDE
- R = ROSSO
- B = BIANCO

COMMUTATORE RTCP 900036

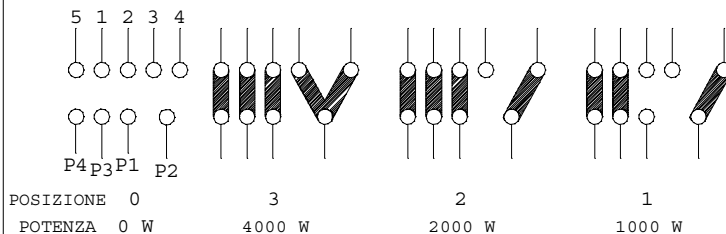

SCALA	DATA 30/05/1994	SOSTITUISCE IL N°	SOSTITUITO DAL N°	DISEGN. PROMIND
SERVE PER FORNELLO ELETTRICO		N° COD. _____		
DENOMINAZIONE SCHEMA ELETTRICO		DISEGNO N° 1124	VISTO	
MOD. EFP01 380/415V+N~50/60Hz				