



MOD : E9/CPA8-N

Production code : DICPE98A

10/2023



OPTIMA 900 EVO - CUISEURS À PÂTES E9/CPA8-N



2 PANIERS, ÉL. SUR COFFRE

SPÉCIFICATIONS TECHNIQUES:

Dimensions exterieure - LxPxH (cm)	80x90x85
Capacité de la cuve (lt-GN)	40+40
Puissance totale (kW)	9+9=18
IPX5	●

SPÉCIFICATIONS SUPPLÉMENTAIRES:

Dimensions cuve - LxPxH (cm)	30,5x51x27,5
Energie (N)	400V 3N 50/60Hz
Poids (kg)	81
Volume (m3)	1

Les cuves sont réalisées en acier inoxydable anti corrosion AISI 316, avec des grands rayons pour faciliter le nettoyage. Les paniers (option) sont réalisés en acier inoxydable AISI 304 et sont équipés de poignées anti-chaaleur. Electrovanne pour charger l'eau.

Version gaz: Bruleur acier à flamme stabilisée. Thermocouple et vanne de sécurité. Allumage piezzo.

Version electrique: résistance chauffantes blindées, réglage de la chauffe avec contacteur 4 position et thermostat de sécurité.

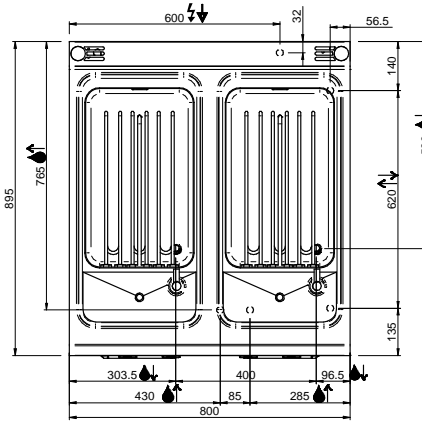
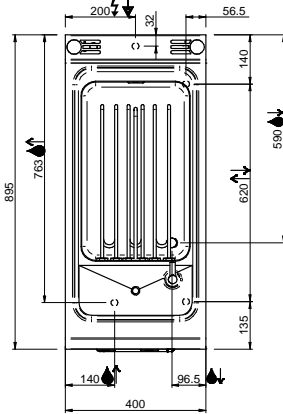
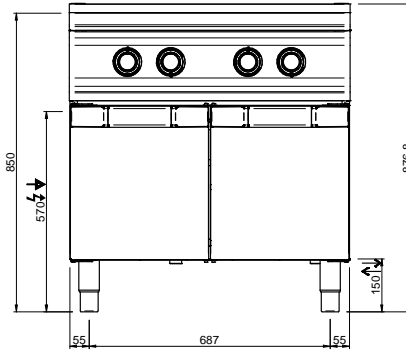
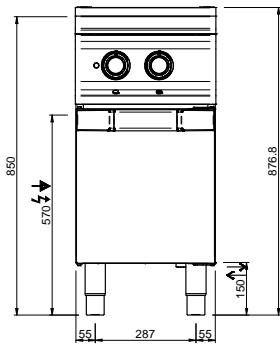

LEGENDA SIMBOLI / LEGEND



INGRESSO GAS / GAS INLET
(EN 10226-1) Ø M 1/2"



INGRESSO ACQUA /
WATER INLET Ø M 1/2"



ATTACCO EQUIPOTENZIALE /
EQUIPOTENTIAL



ALIMENTAZIONE ELETTRICA /
POWER SUPPLY



SCARICO ACQUA / OLII
WATER / OILS DRAIN



REGOLAZIONE PIEDINI /
FEET ADJUSTMENT (h 0/+50)
/ TOP VERSION (h 0/+5)